



S SERIES, SOLENOID VALVES									
Water Service					Steam Service				
MODEL NUMBER	NPT SIZE	ORIFICE SIZE	CV FACTOR	SHIP WGT. Lbs./(kg)	MODEL NUMBER	NPT SIZE	ORIFICE SIZE	CV FACTOR	SHIP WGT. Lbs./(kg)
S-5-W	1/2"	5/8"	4	3 (1.4)	S-5-S	1/2"	5/8"	4.7	3 (1.4)
S-3-W	3/4"	3/4"	5	4 (1.8)	S-3-S	3/4"	3/4"	8.8	4 (1.8)
S-1-W	1"	1"	13	6 (2.7)	S-1-S	1"	1"	11.5	6 (2.7)
S-1-1/4-W	1 1/4"	1-1/8"	15	8 (3.6)	S-1-1/4-S	1 1/4"	1-1/8"	15	8 (3.6)
S-1-1/2-W	1 1/2"	1-1/4"	22.5	10 (4.5)	S-1-1/2-S	1 1/2"	1-1/4"	22.5	10 (4.5)
S-2-W	2"	1-3/4"	43	12 (5.4)	S-2-S	2"	1-3/4"	43	12 (5.4)

S Series Features and Benefits

IMPROVES PROCESS CONTROL:

- ◆ Provides on/off control of water, steam, air, or gases in a variety of heating, cooling, or fluid replenishing applications.

RUGGED CONSTRUCTION:

- ◆ Brass valve body with:
Buna-N-seals (water service)
Ethylene Propylene seals (steam service)

MOISTURE RESISTANT TERMINAL ENCLOSURE:

- ◆ Epoxy encapsulated enclosure rated for NEMA 1, 2, 3, 3S, 4 and 4X applications.

CERTIFICATIONS:

- ◆ cULus and CSA (steam valves), CSA (water valves).

CAPACITIES:

- ◆ Sizes: 1/2-inch through 2-inch FNPT.
- ◆ Two-way, normally closed valve available in 120 or 240 volts.
- ◆ Ambient temperature range: 32°F (0°C) to 125°F (52°C).
- ◆ Voltages: other AC and DC voltages available in 50 or 60 Hz.

- ◆ Minimum pressure differential: 5 PSI.
- ◆ Minimum operating pressure: 10 PSI.
- ◆ Single phase only.
- ◆ Maximum pressure:
Water service: 125 PSI at 180°F (82°C).
Steam service: 50 PSI at 300°F (149°C).

OPTIONS AVAILABLE (consult factory):

- ◆ Stainless steel valve bodies.
- ◆ Normally open valves.
- ◆ Higher pressure ratings.
- ◆ Explosion resistant enclosures.
- ◆ Three-way valves.
- ◆ Slow opening valves.
- ◆ Fluoropolymer seals.
- ◆ Low-pressure drop valves for operating pressures below 10 PSI.

NOTE: Always use a strainer with solenoid valves.

DIMENSIONS

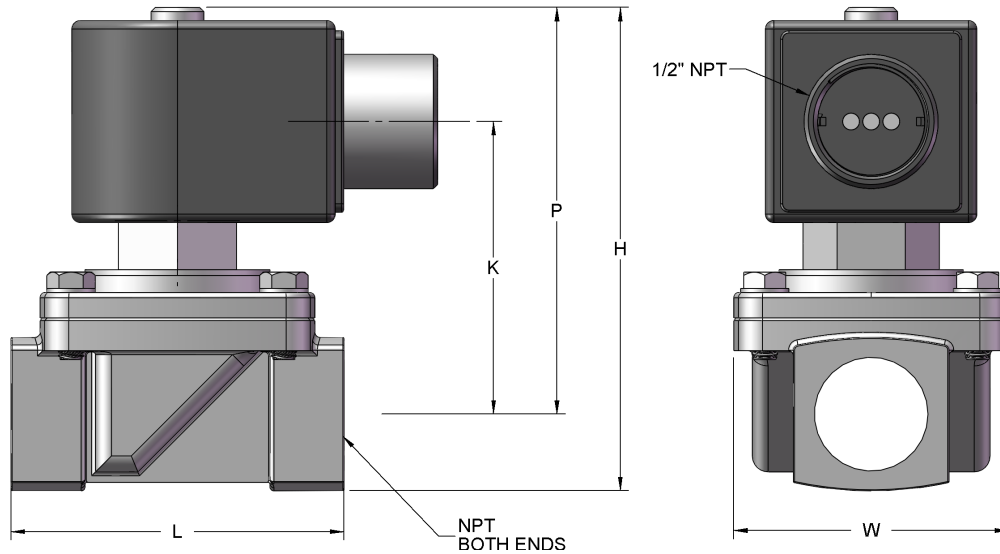

Water Service					
Model	H	K	L	P	W
S-5-W	3.38"	1.94"	2.75"	2.8"	2.28"
S-3-W	3.66"	2.1"	2.81"	2.96"	2.28"
S-1-W	5.64"	3.15"	3.75"	4.01"	3.36"
S-1-1/4-W	5.64"	3.15"	3.66"	4.01"	3.56"
S-1-1/2-W	6.11"	3.3"	4.38"	4.16"	3.92"
S-2-W	7.33"	3.71"	5.06"	4.57"	4.87"

Steam Service					
Model	H	K	L	P	W
S-5-S	4.05"	2.52"	2.75"	3.48"	2.28"
S-3-S	4.34"	2.68"	2.81"	3.65"	2.28"
S-1-S	5.81"	3.22"	3.75"	4.19"	3.14"
S-1-1/4-S	5.81"	3.22"	3.66"	4.19"	3.56"
S-1-1/2-S	6.29"	3.37"	4.38"	4.34"	4.1"
S-2-S	7.51"	3.78"	5.06"	4.75"	4.71"

SOLENOID VALVE ORDERING INFORMATION

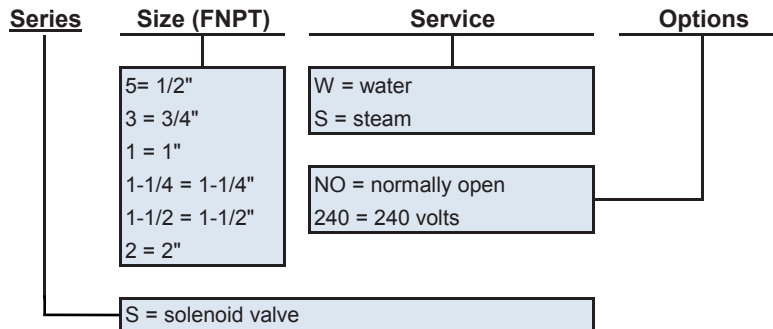

ORDERING EXAMPLE:

S-1-S

Solenoid valve, 1" NPT, steam service.

CONTACT FACTORY FOR SIZING ASSISTANCE

